

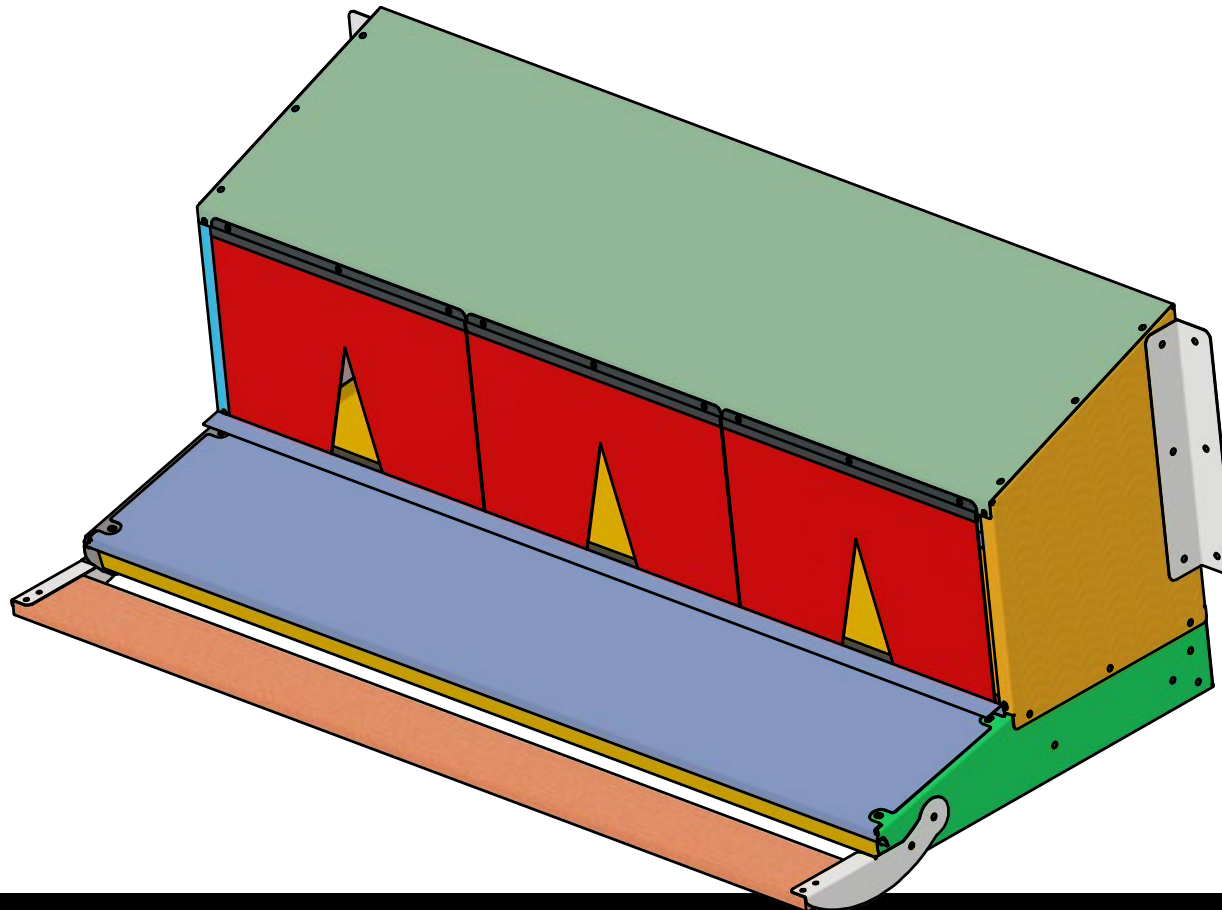

# 48" NEST BOX ASSEMBLY INSTRUCTIONS



feathermanequipment.com | <https://bit.ly/4nI0KsT>



# TABLE OF CONTENTS

<b>Parts List .....</b>	<b>3</b>
<b>Assembly Instructions.....</b>	<b>9</b>
Step 1: Side and Base Assembly.....	9
Step 2: Installing the Lid and Lid Holder .....	11
Step 3: Install Roost Support .....	12
Step 4: Attach Perch Board .....	13
Step 5: Install Side Panels.....	14
Step 6: Install Lid Support & Curtain.....	15
Step 7: Top Cover and Mounting Bracket.....	16

# SAFETY FIRST, STEWARDSHIP ALWAYS.

At Featherman, we design equipment with intention—for your birds, your land, and the long run. Whether you're retrofitting a current coop or starting from scratch, the 48" Nest Box makes egg collection simpler while supporting the health of your flock and the efficiency of your workflow.

Follow these instructions carefully, and inspect all parts before and after installation. Improper use or modification outside these guidelines may affect performance or void your warranty.

Scan for video tips and how-to guides:  
<https://bit.ly/4nI0KsT>



## TOOLS NEEDED

- Nut driver
- 7/16" socket
- Phillips head screwdriver or #2 bit
- Anti-seize lubricant
- Gloves and protective eyewear (recommended)

## PARTS LIST

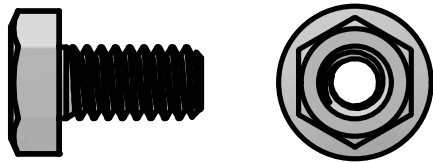

Part	Qty
Bolts, washers, and lock nuts	60

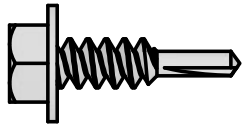

**Part**

**Qty**

Sheet Metal Screws #8

9



Wood Grip Screws #8 x 1/2"

4

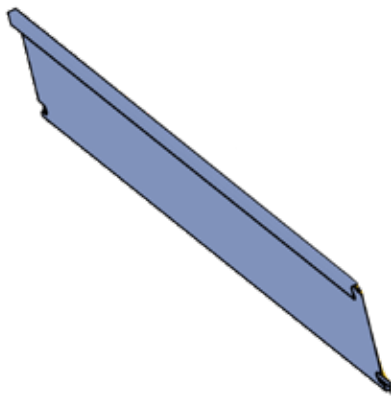

Egg Box Lid

1

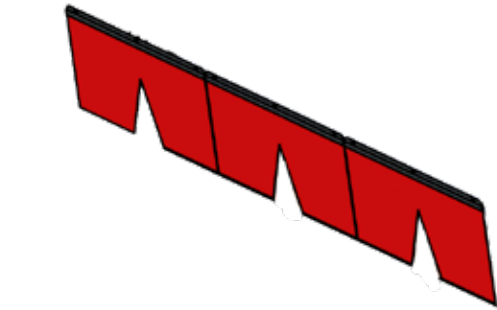

**Part**

**Qty**

Curtain

1

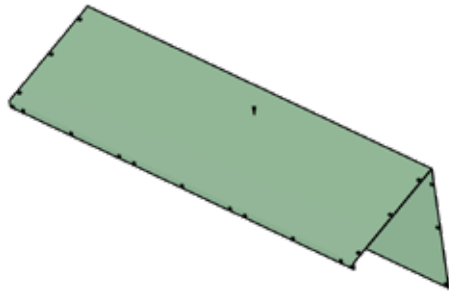

Top Cover

1

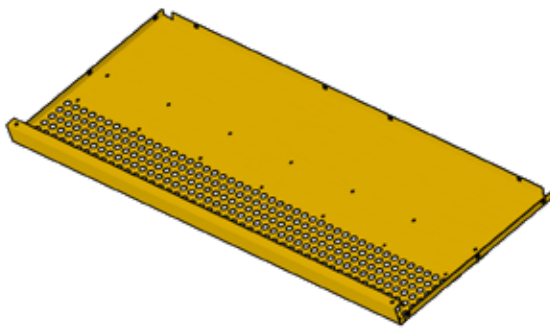

Base

1

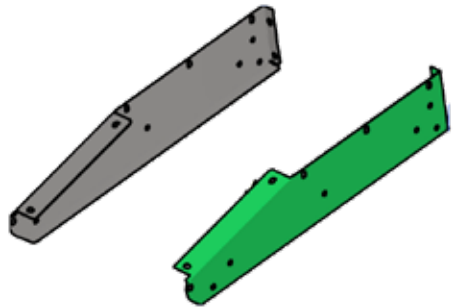

**Part**

**Qty**

Bottom Sides

2

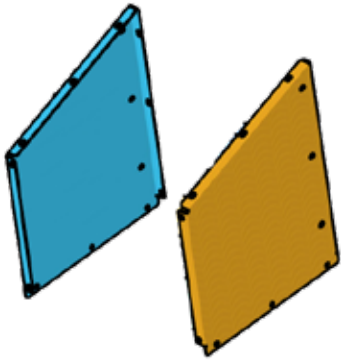

Sides

2



Lid Support

1



**Part**

**Qty**

Mounting Bracket

1

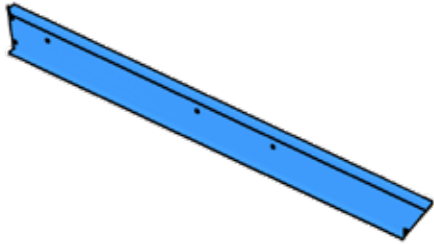

Back Bottom Panel

1

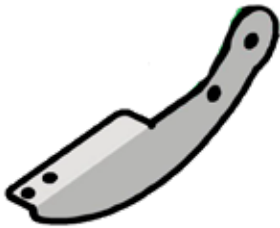

Roost Support

2

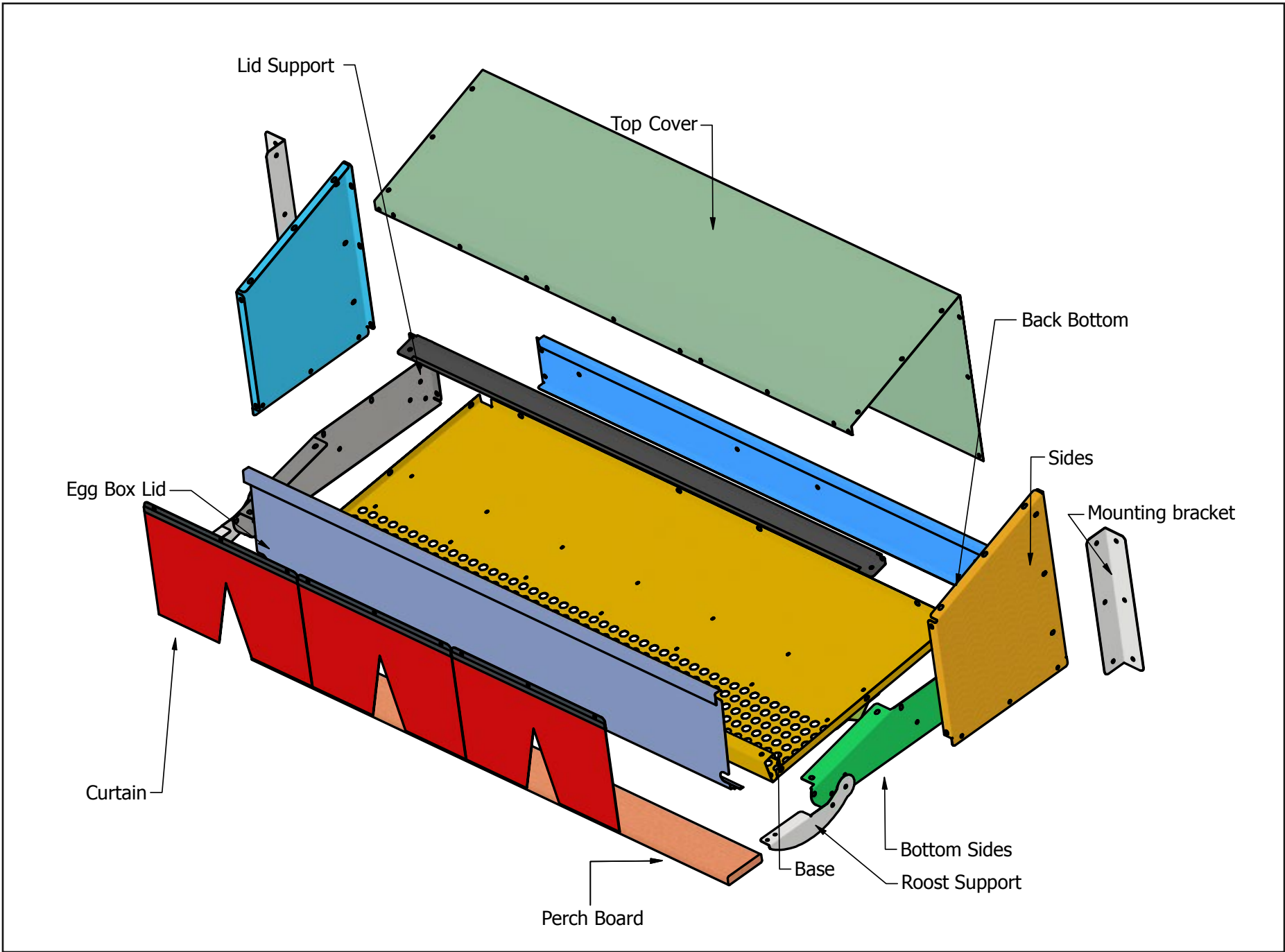

# STEP-BY-STEP ASSEMBLY

## Step 1: Side and Base Assembly

- Attach side panels to the base using 1/4" x 1/2" hex bolts and lock nuts (x4 total).

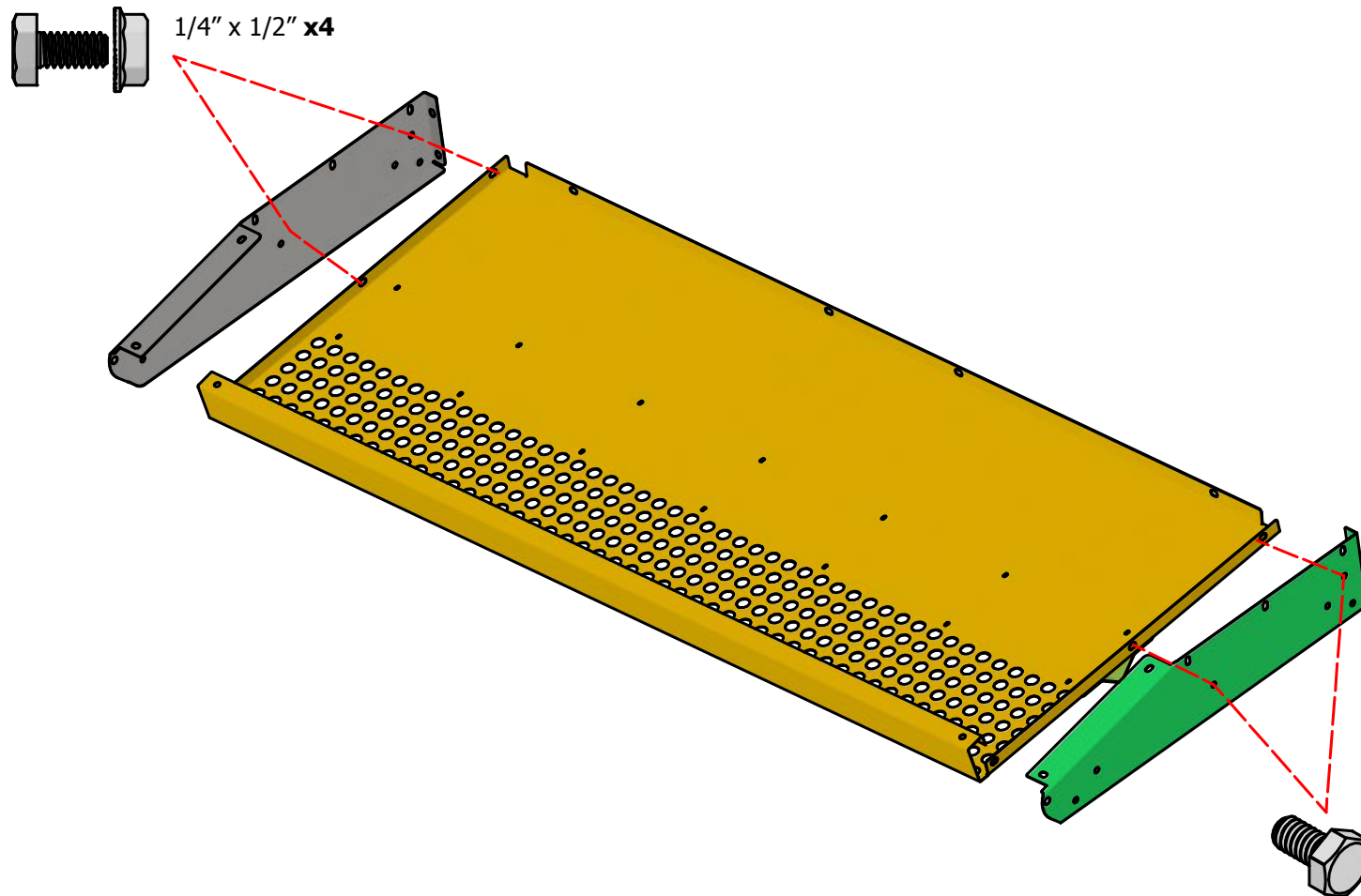

### Assembly Tip

Do not fully tighten bolts until egg box lid is installed.

Use lock nuts for all 1/4" bolts unless otherwise noted.

All bolts: 1/4" x 1/2" unless stated otherwise.

Apply a tiny drop of anti-seize lubricant on each lock nut

## Step 1: Side and Base Assembly

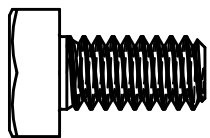
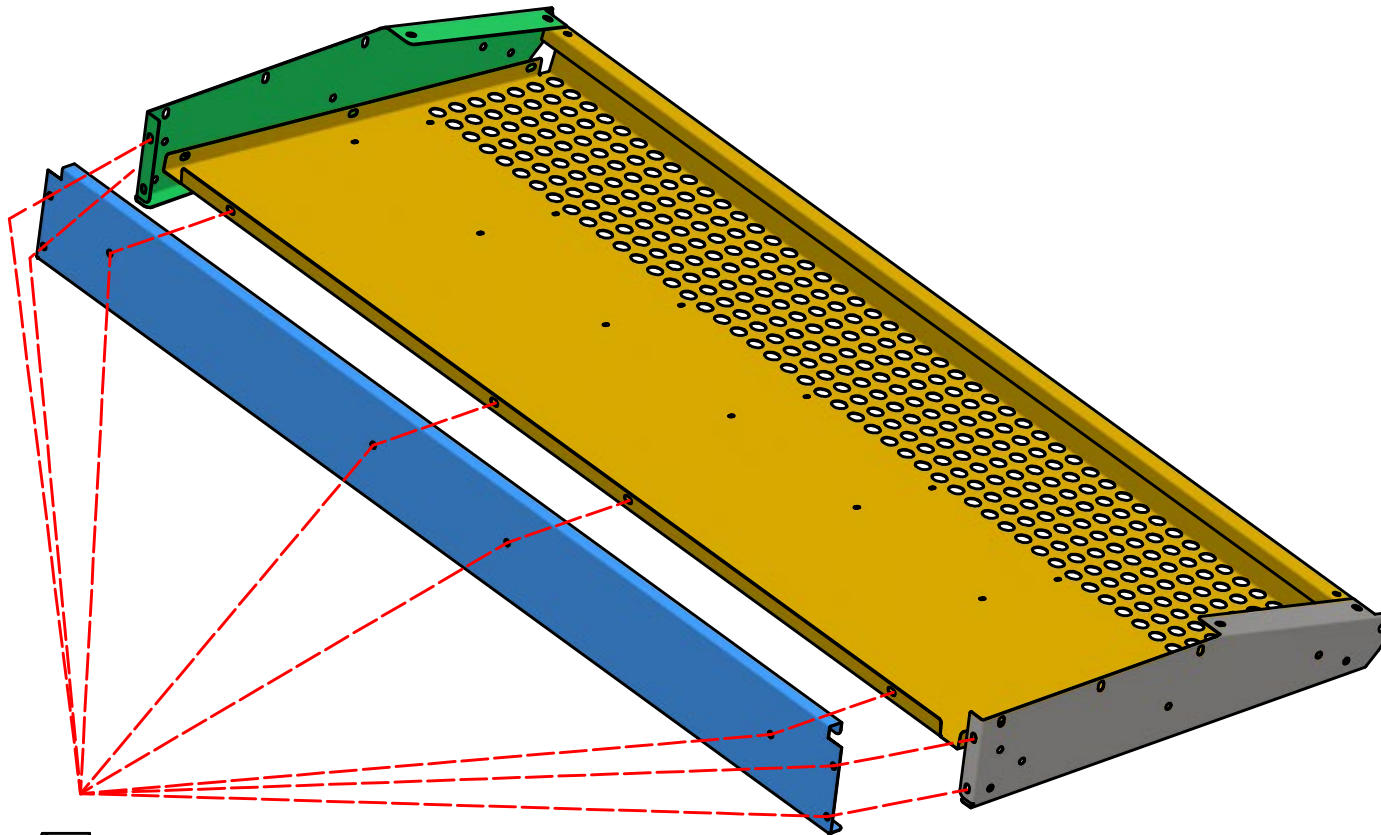

1/4" x 1/2" x8  
Use lock nut to fasten

**Step 2: Installing the Lid and Lid Holder**

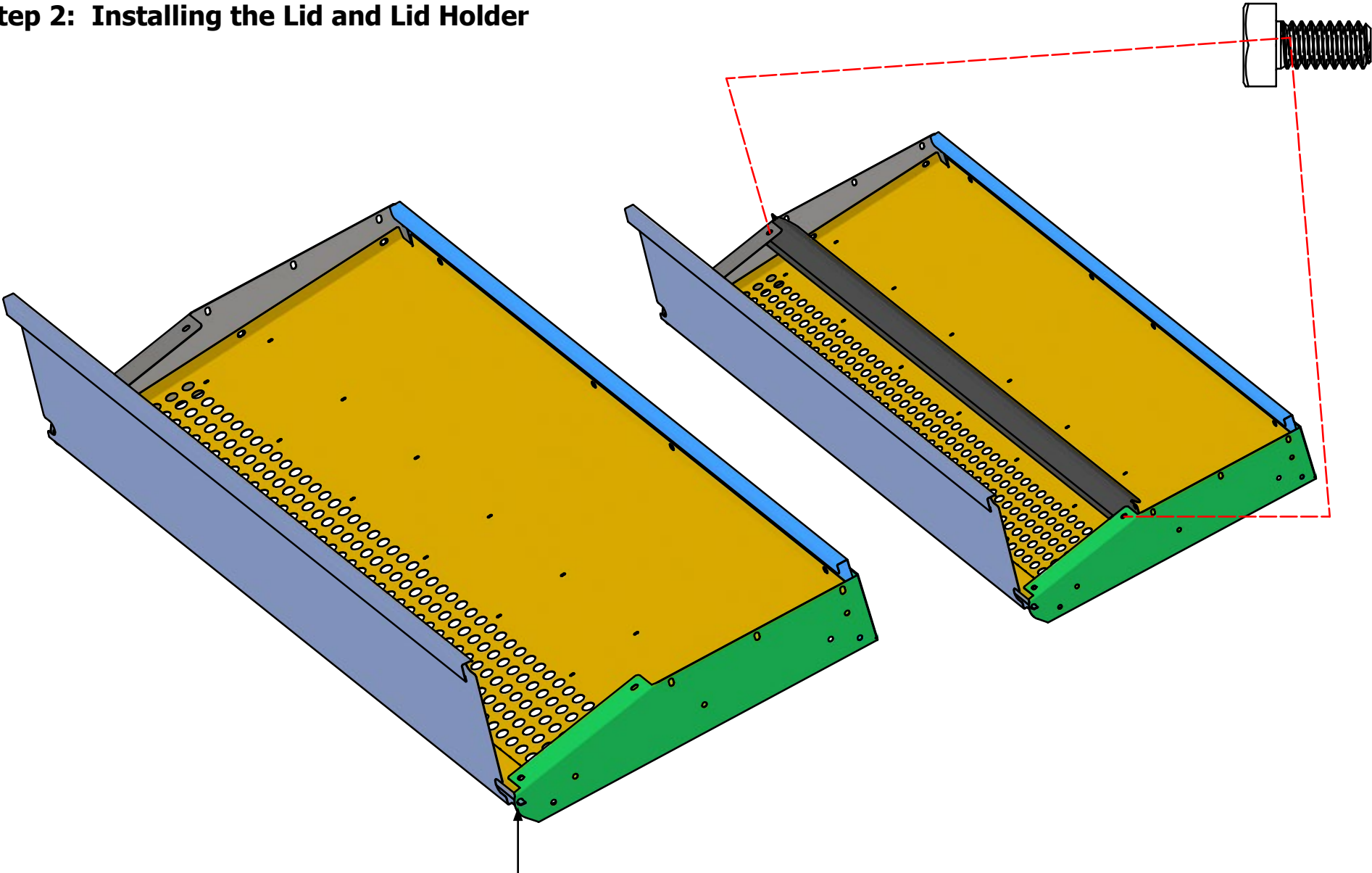

Insert egg box lid hinge tab into sides.

### Step 3: Install Roost Support

- Position roost support as shown or on opposite side as preferred
- Secure with 1/4" x 1/2" bolts and lock nuts (x4).

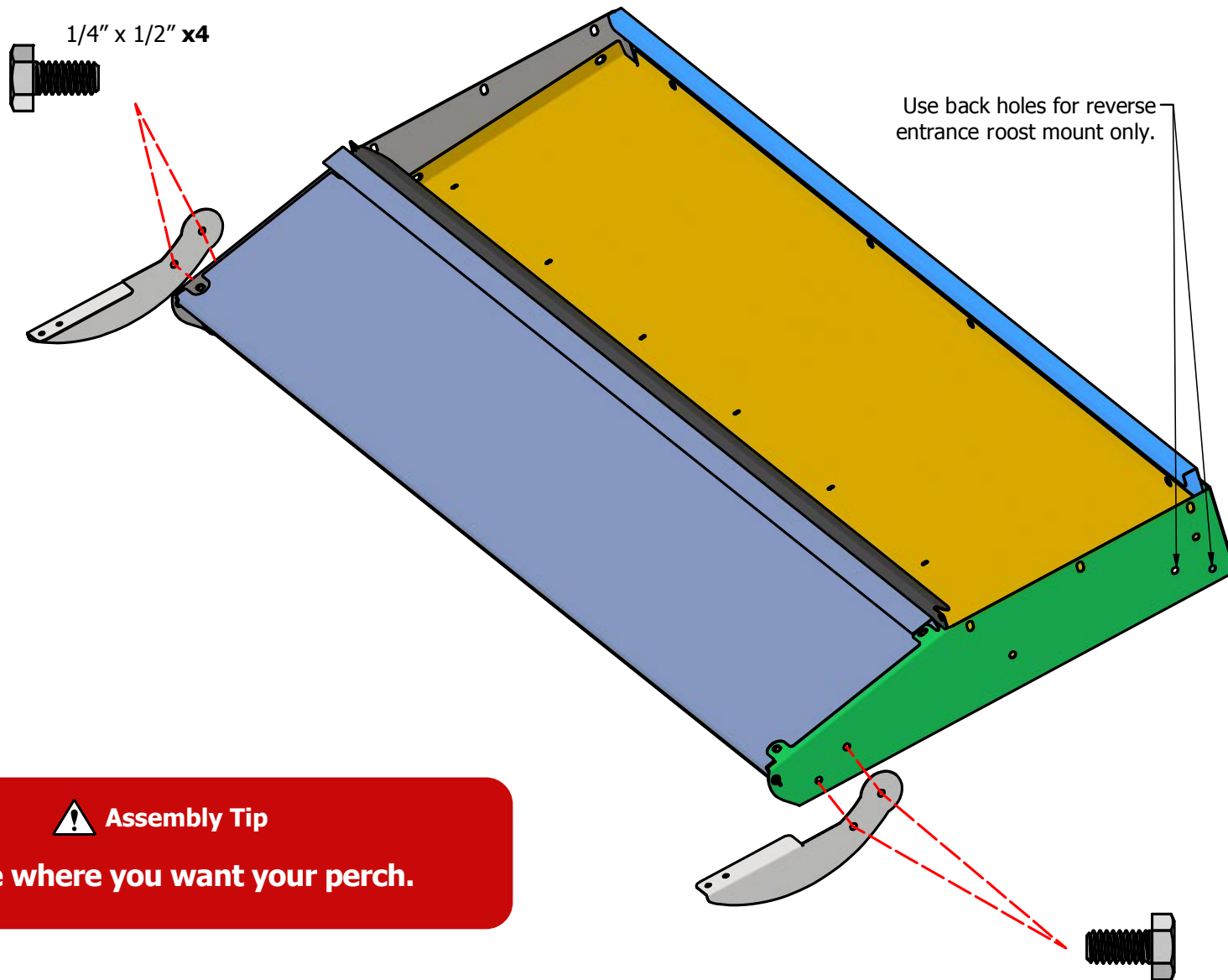

 **Assembly Tip**

**Decide where you want your perch.**

## Step 4: Attach Perch Board

- Fasten using wood grip screws #8 x 1/2" (x4) and Phillips head bit.

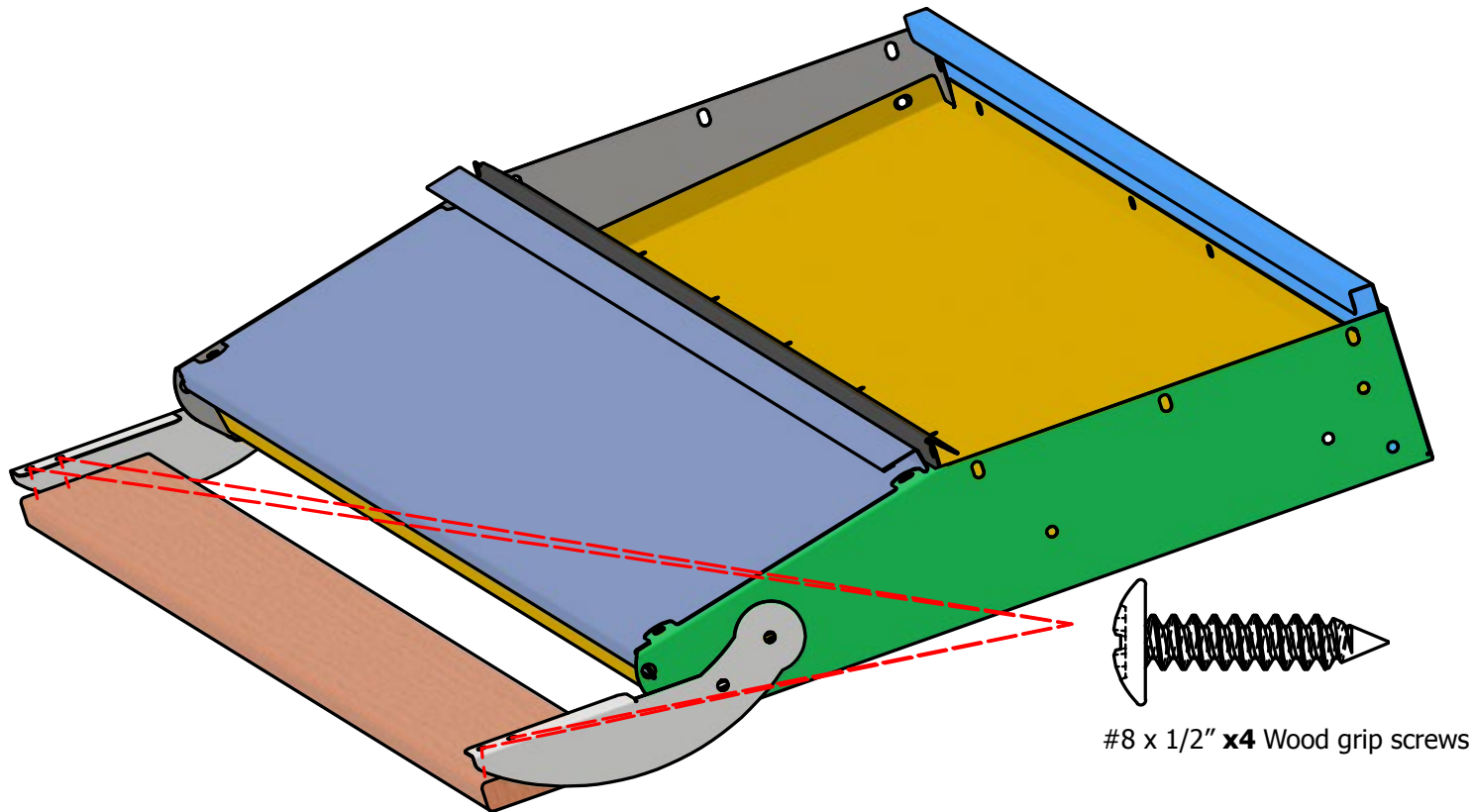

## Step 5: Install Side Panels

- Secure using 1/4" x 1/2" bolts and lock nuts (x6).
- Tighten all bolts only after lid is fully aligned.

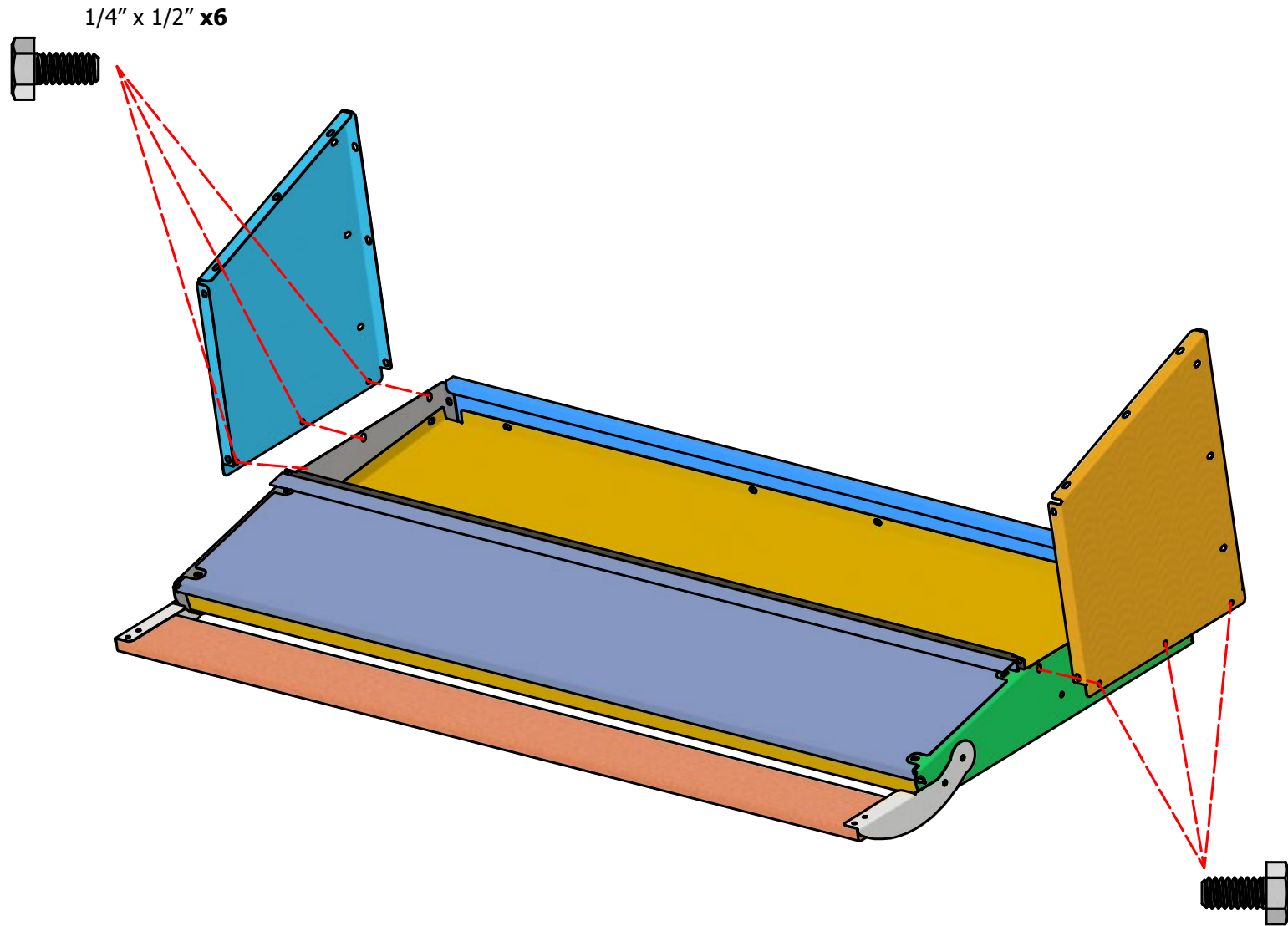

## Step 6: Install Lid Support & Curtain

- Attach lid support and curtain using sheet metal screws #8 (x3).
- Confirm fit before final tightening.

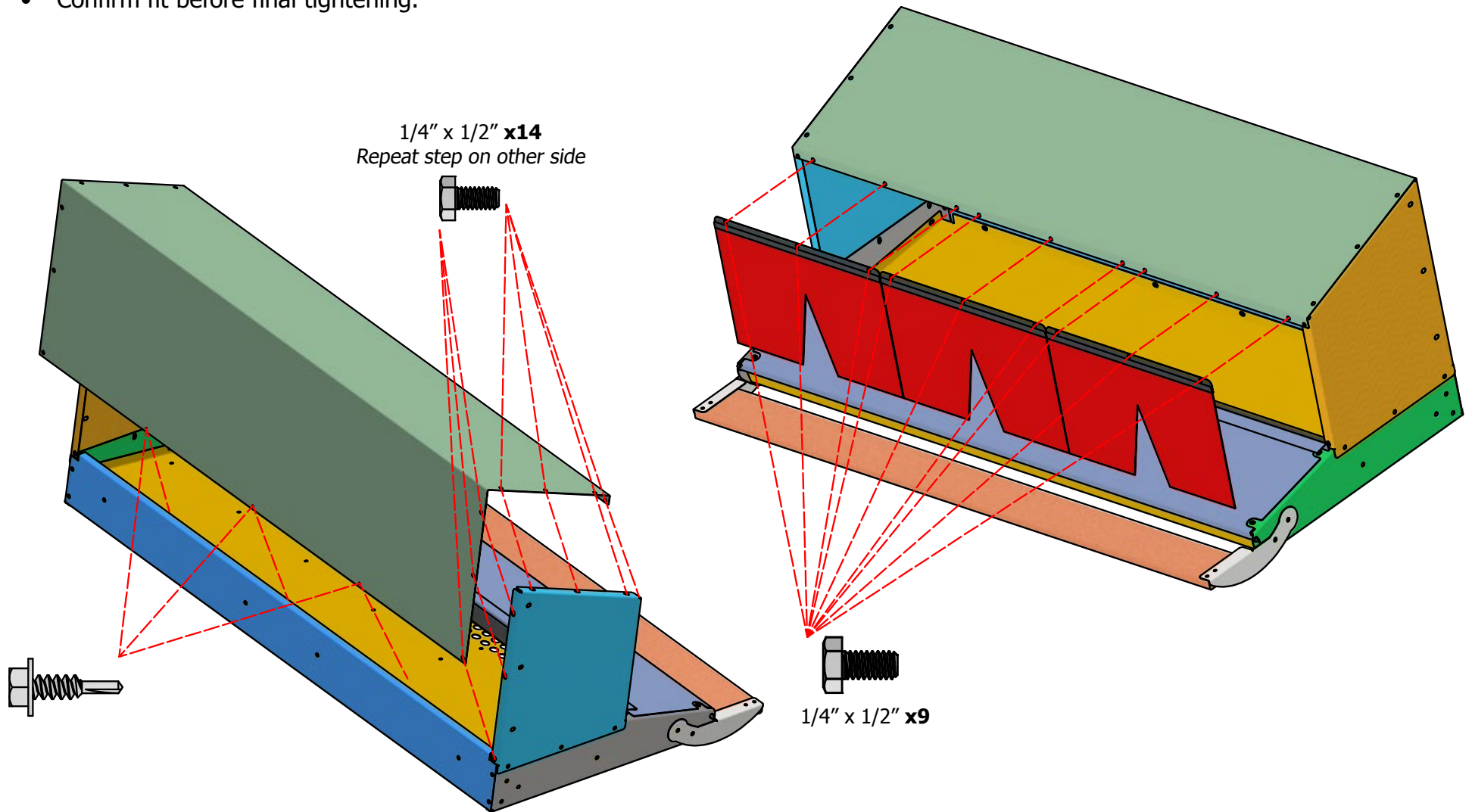

## Step 7: Top Cover and Mounting Bracket

- Position top cover over the entire assembly.
- Secure with 1/4" x 1/2" bolts and lock nuts (x16).
- Attach mounting bracket as needed (x6 bolts).

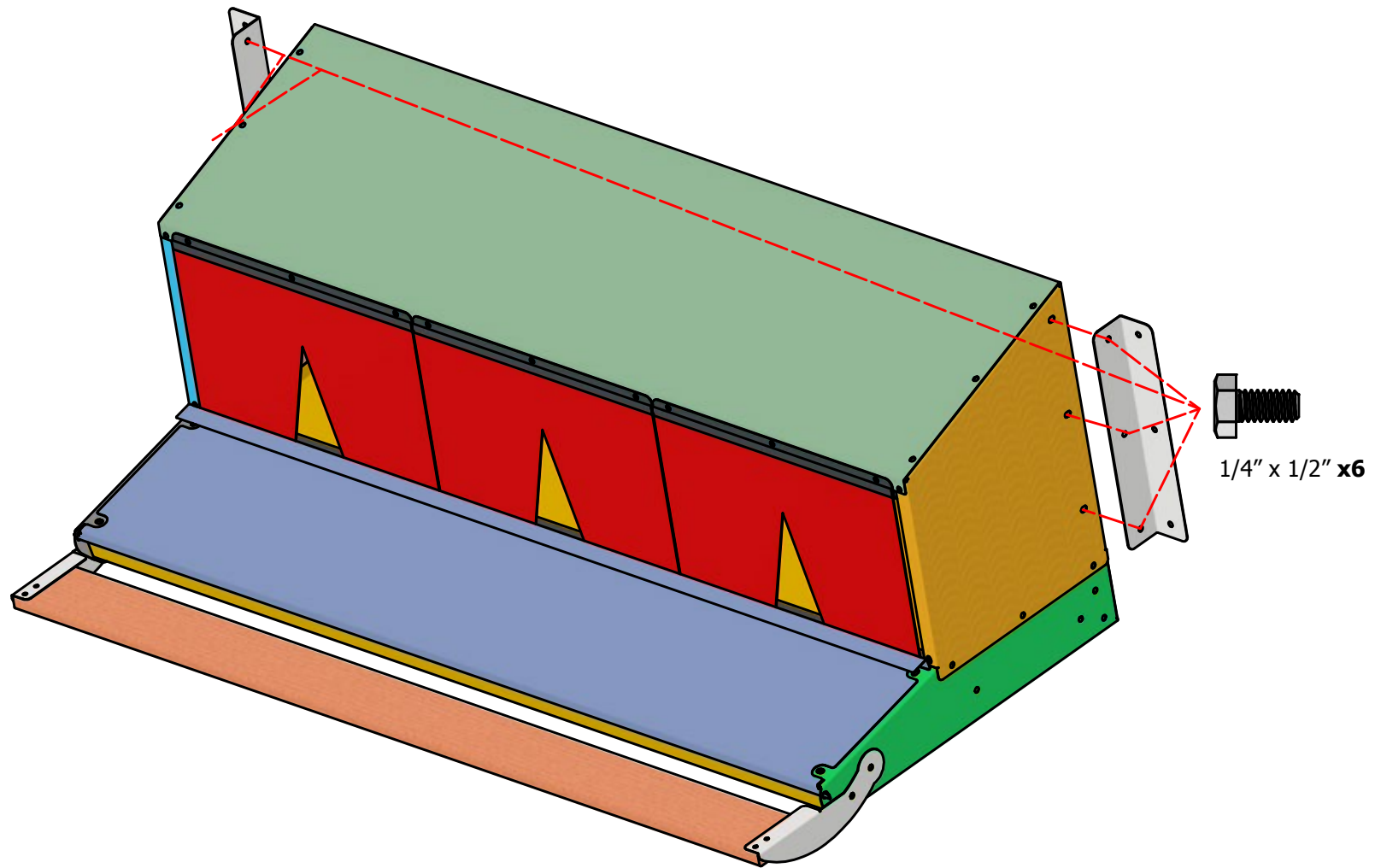

# Assembled View

Front Configuration

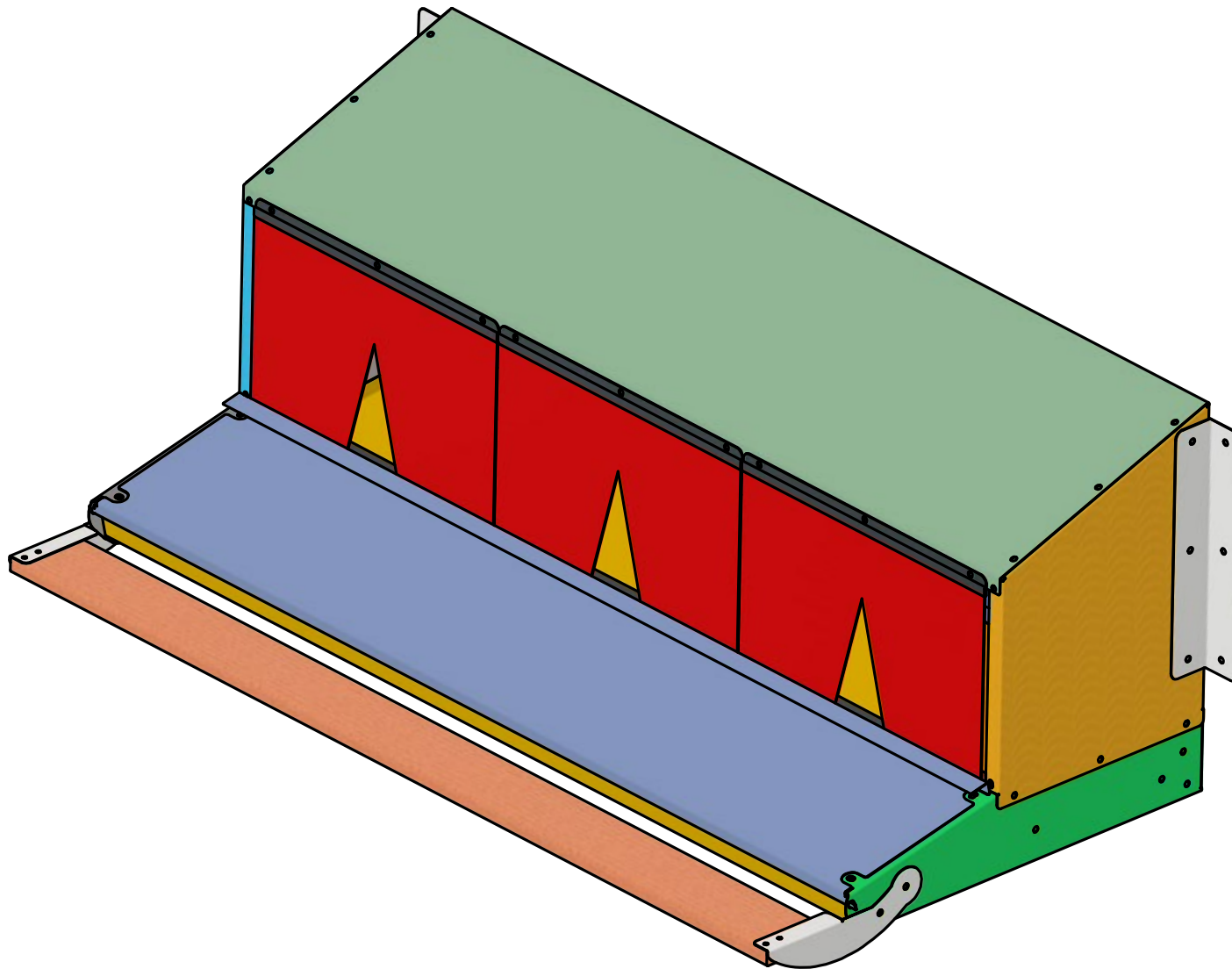

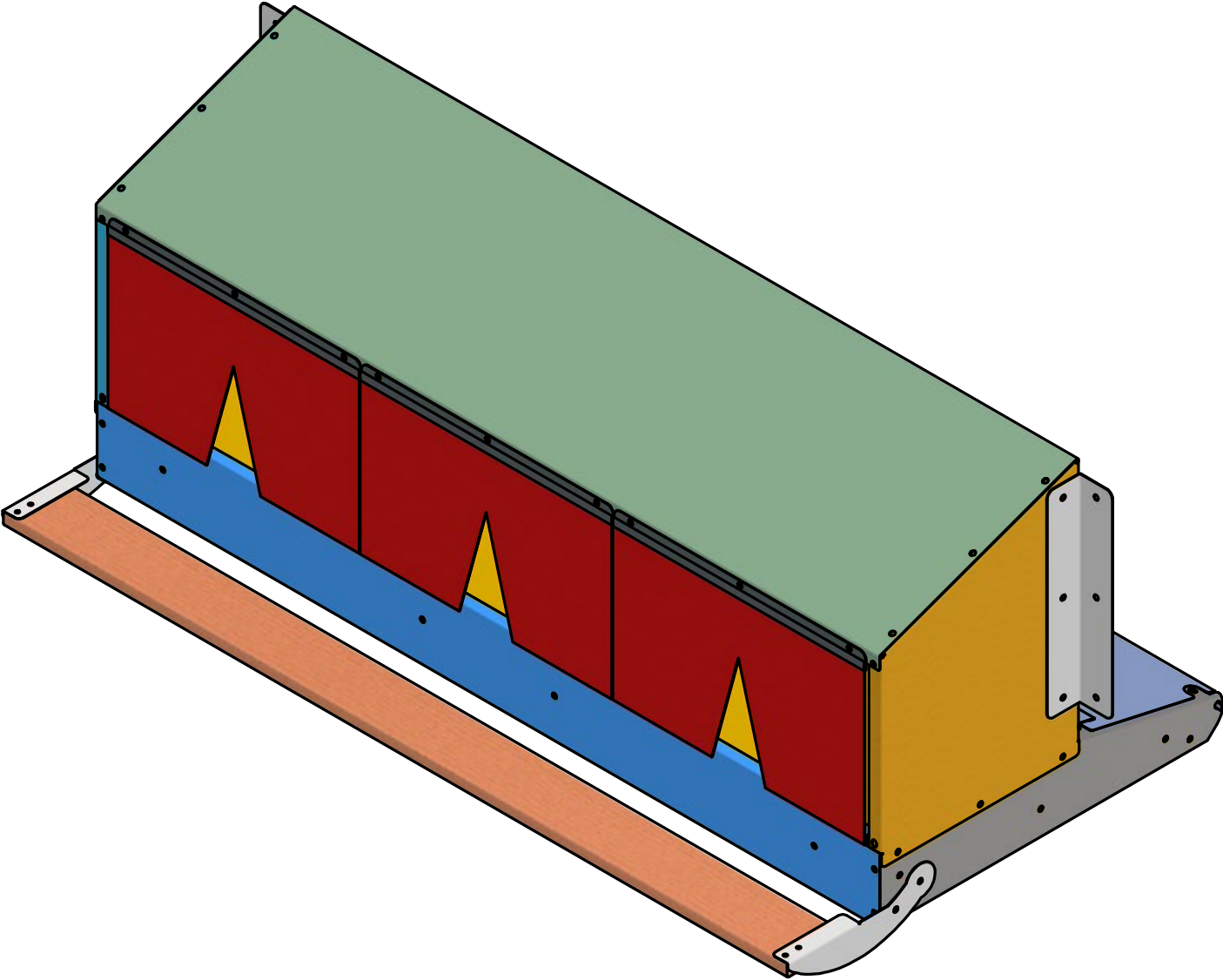

# DID YOU KNOW?

You can turn your Featherman processing equipment into a community resource.

Our rental program was designed to make poultry processing more accessible—whether you need to rent equipment for a small batch of birds or want to earn income by renting out your own gear.

It's a simple way to support your community, stretch your investment further, and help others get started in pastured poultry.

Learn more and sign up here:

**<https://bit.ly/4eseV0E>**

Have questions? We're here to help:

**660.684.6035 | [customerservice@feathermanequipment.com](mailto:customerservice@feathermanequipment.com)**

# WE'RE HERE IF YOU NEED US.

If you ever need a replacement part, have questions, or want to make sure you're getting the most out of your equipment, we're here to help.

**660.684.6035 | [customerservice@feathermanequipment.com](mailto:customerservice@feathermanequipment.com)**

For video tips and how-to guides, scan the QR code on this page or visit:  
**<https://bit.ly/4nI0KsT>**

**Scan for video tips  
and how-to guides**





## JOIN OUR COMMUNITY.

Thank you for choosing Featherman.

Our work is about more than gear—it's about the stories you create and the way you care for your birds and your farm. Share your Nest Box setup and tag us on social:

 **@feathermanequipment**

 **@feathermanequipment**

 **Featherman Equipment**

 **Featherman Equipment**

Thank you for trusting us to be a small part of your poultry setup or farm's bigger picture. Here's to safe, thoughtful stewardship of your flocks for years to come.

*—The Featherman Team*